

TEAM DURANGO DEX410/R SETUP SHEET

PRINT

SUBMIT

NAME / NOM: Simon Crabb

DATE / DATUM: 5 Sept 2010

SETUP BLATT / FICHE DE RÉGLAGE V1.0 E

EVENT / VERANSTALTUNG: Club Meeting

TRACK / STRECKE / PISTE: TORCH

AIR TEMP / UMGEBUNGSTEMP.: 15 °

TRACK SIZE / STRECKENGRÖSSE / TAILLE DE LA PISTE: Small

SURFACE / STRECKENBELAG / TYPE DE SURFACE: Astro

TRACTION LEVEL / GRIFF / ADHÉRENCE: High

CONDITIONS / WETTER / NIVEAU D'HYDROMÉTRIE: Dry

FRONT VORN AVANT

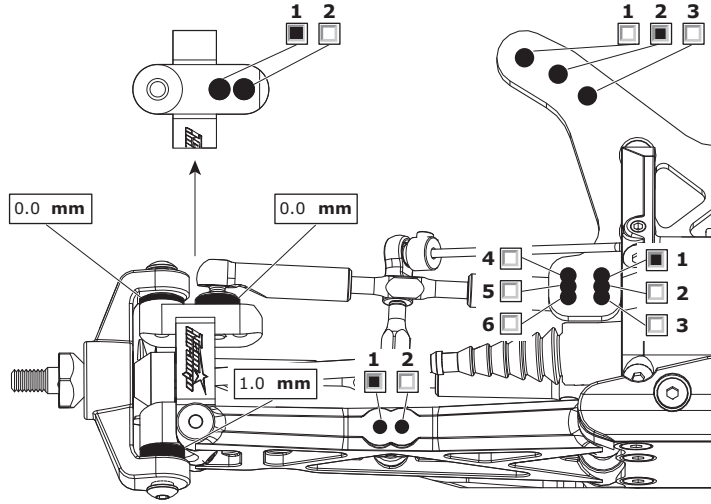

REAR HINTEN ARRIÈRE

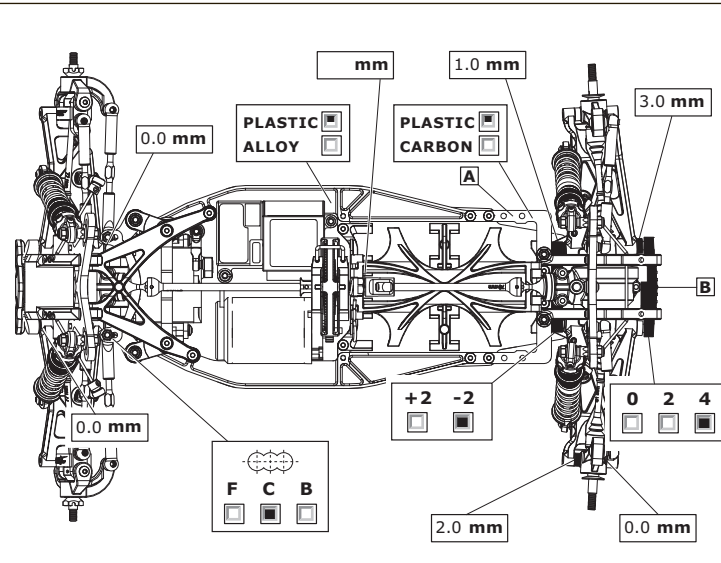
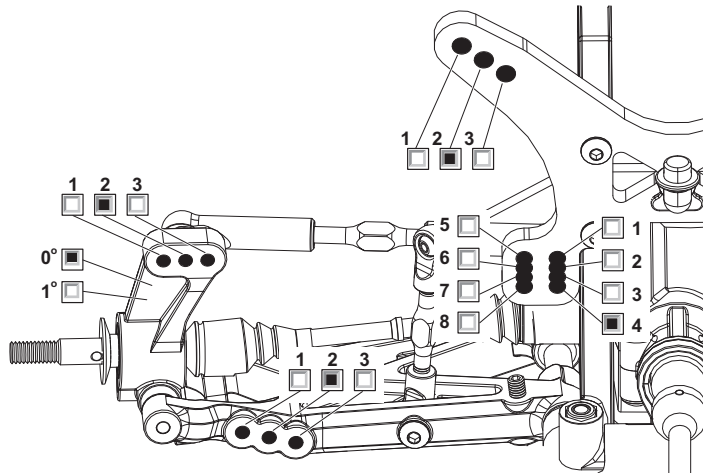

FRONT SHOCKS / VORNE DÄMPFER / AVANT AMORTISSEURS

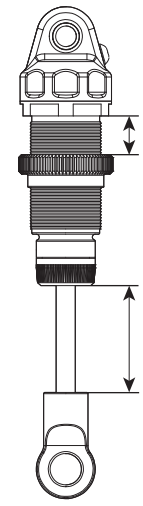

SPRINGS FEDERN	RESSORTS
Dark Blue	
REBOUND REBOUND	REBOND
0	%
PRELOAD FEDERVORSpannung	PRÉCONTRAINTÉ
	mm
OIL WT. ÖLVISKOSITÄT	GRADE HUILE
500	cST
PISTON KOLBEN	PISTON
ghea 2 x 1.3mm	
LENGTH LÄNGE	LONGUEUR
	mm
NOTES NOTIZEN	REMARQUES

REAR SHOCKS / HINTEN DÄMPFER / ARRIÈRE AMORTISSEURS

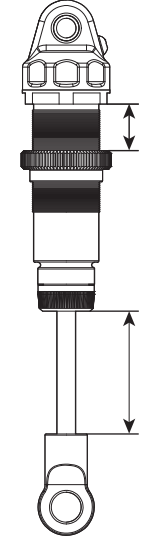

SPRINGS FEDERN	RESSORTS
Black	
REBOUND REBOUND	REBOND
0	%
PRELOAD FEDERVORSpannung	PRÉCONTRAINTÉ
	mm
OIL WT. ÖLVISKOSITÄT	GRADE HUILE
500	cST
PISTON KOLBEN	PISTON
ghea 3 x 1.4mm	
LENGTH LÄNGE	LONGUEUR
	mm
NOTES NOTIZEN	REMARQUES

TYRES REIFEN PNEUS

FRONT	REAR
BRAND / HERSTELLER / MARQUE	Sch 2wd Minispike Sch Minispike
COMPOUND / MISCHUNG / COMPOUND	Blue Blue
INSERT / EINLAGEN / INSERT	Answer Closed Cell Answer Firm
WHEEL / FELGE / JANTE	AE AE
NOTES / NOTIZEN / REMARQUES	fr:i/o row removed r:i/2o row removed

RIDE HEIGHT BODENFREIHEIT / GARDE AU SOL	19 mm
CAMBER ANGLE STURZ / ANGLE DE CARROSSAGE	2 °
CASTOR ANGLE NACHLAUF / ANGLE DE CHASSE	kit °
TOE IN/OUT VONSPUR/NACHSPUR / ANGLE DE PINCEMENT	+/- 0 °
DIFF. OIL DIFF. ÖL / HUILE DE DIFF.	20000 .wt
SWAY BAR STABILISATOR / BARRE ANTI-ROULIS	None mm
SWAY BAR LINK STABILISATOR HEBELÄNGE / LIÈV DE LA BARRE ANTI-ROULIS	mm
NOTES NOTIZEN / REMARQUES	

RIDE HEIGHT BODENFREIHEIT / GARDE AU SOL	19 mm
CAMBER ANGLE STURZ / ANGLE DE CARROSSAGE	2 °
DIFF. OIL DIFF. ÖL / HUILE DE DIFF.	10000 .wt
SWAY BAR STABILISATOR / BARRE ANTI-ROULIS	None mm
SWAY BAR LINK STABILISATOR HEBELÄNGE / LIÈV DE LA BARRE ANTI-ROULIS	None mm
WISHBONE DROOP AUSFEDERWEG / AXSE / DROOP DES TRIANGLES ARRIÈRES	max mm
NOTES NOTIZEN / REMARQUES	30g lead in front of lipos

MOTOR / MOTOR / MOTEUR	SP v 3 6.5
SPUR GEAR HAUPTZAHNRAD / COURONNE	87
PINION GEAR RITZEL / PIGNON	23
BATTERY AKKU / ACCUMULATEUR	IP 4200
ESC SETTINGS REGLER PROGRAMM / RÉGLAGE DU VARIATEUR	p0 ib4 db4
BALLAST POSITION GEWICHTSPOSITION / POSITION DES LEST	<input type="checkbox"/> SIDES <input type="checkbox"/> SKIDPLATE
WING FLÜGEL / TYPE D'AILERON	kit

RESULTS PLATZIERUNG RÉSULTAT	QUALIFYING POSITION VORLAUFERGEBNIS / POSITION EN QUALIFICATION	1	FINAL POSITION ENDPLATZIERUNG / POSITION FINALE	2
AVERAGE LAP DURCHSCHNITTZEIT / TEMPS AU TOUR MOYEN	BEST LAP SCHWELLESTE RÜNDE / MEILLEUR TEMPS AU TOUR	22.4	RACE TIME REINWÄURER / DURÉE DE LA COURSE	13/311

